

## Pump Specification

### FL150-Series

### 1-1/2 hp High-Head Submersible Effluent Pumps

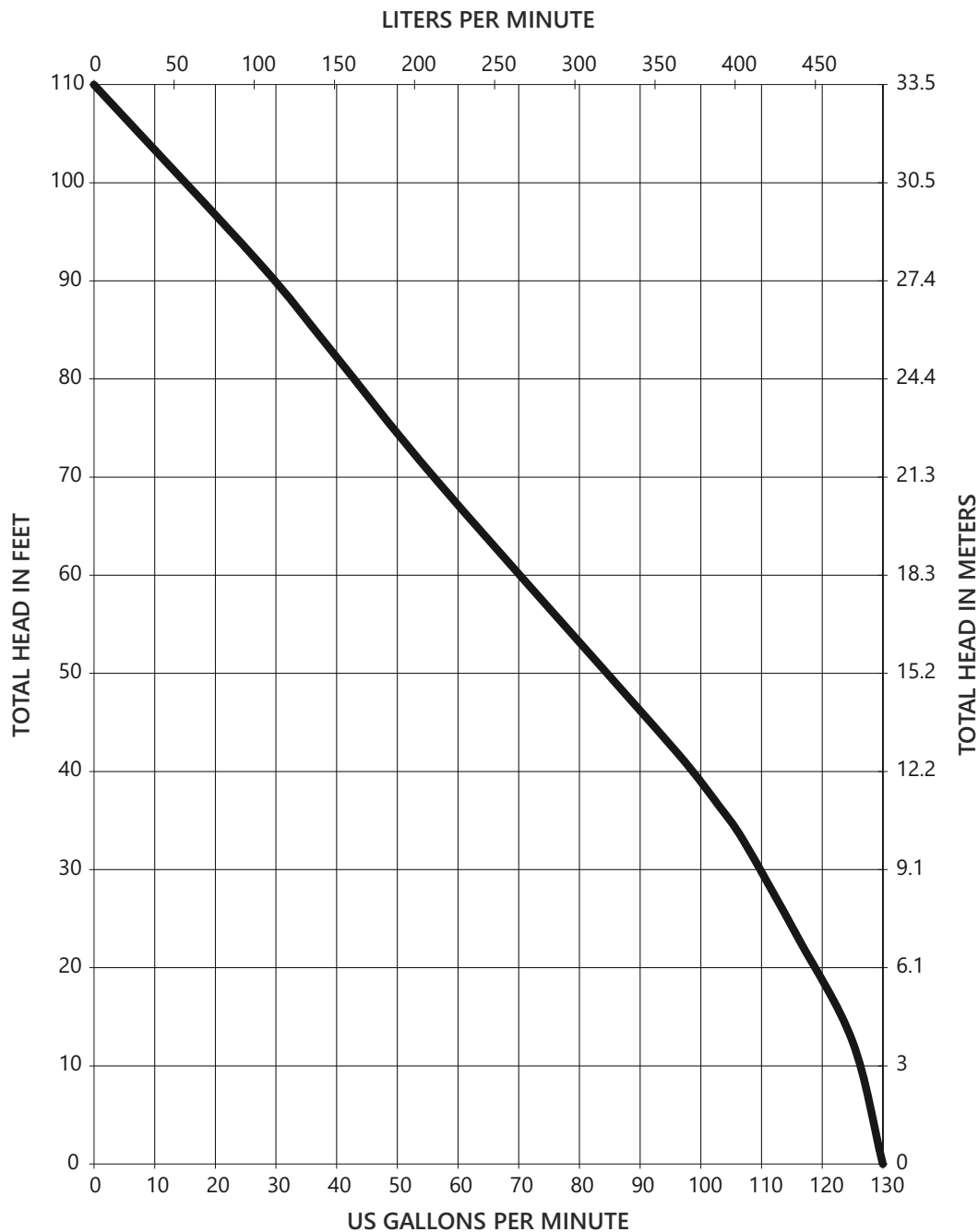
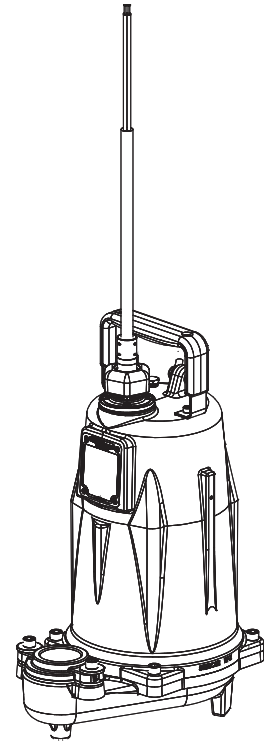

## FL150-Series Dimensional Data

---

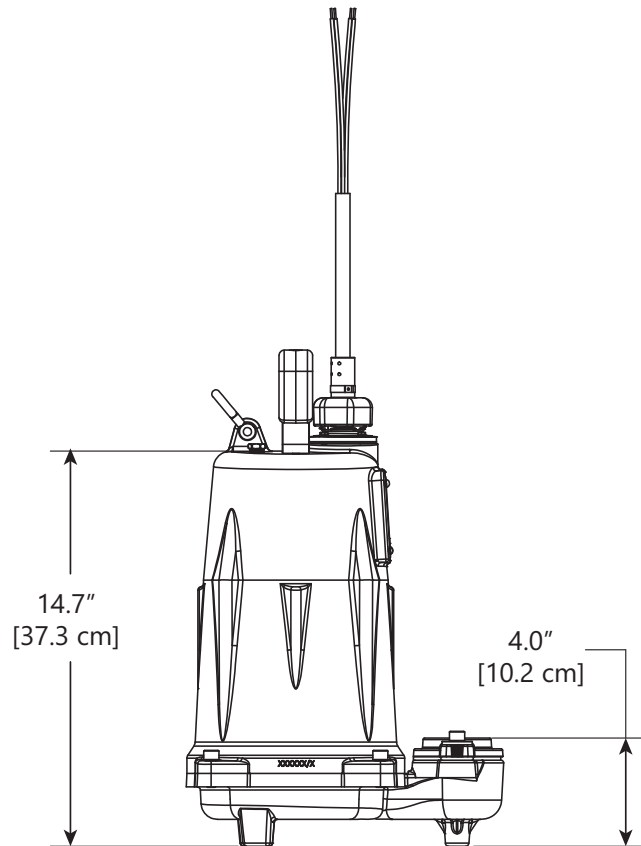
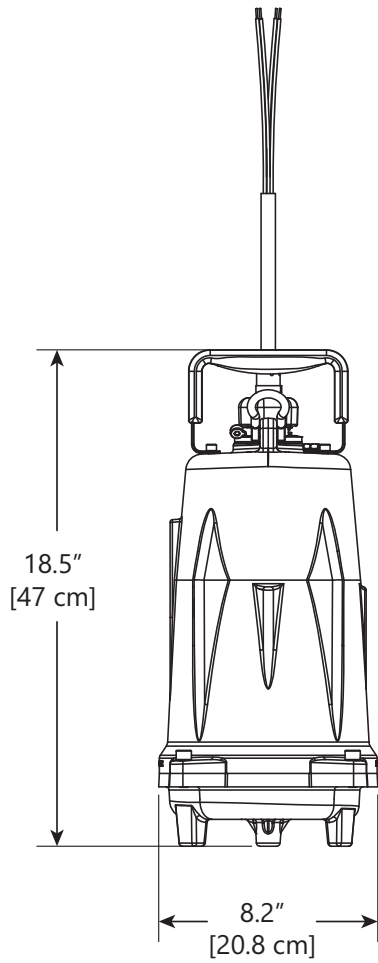
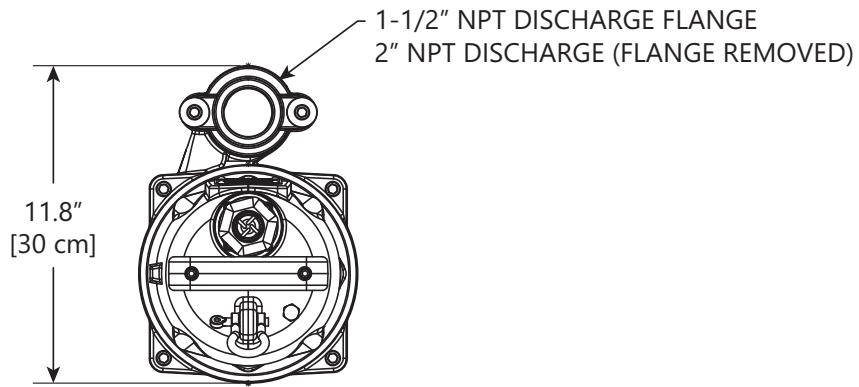

## FL150-Series Electrical Data

MODEL	HP	VOLTAGE	PHASE	SF	FULL LOAD AMPS	LOCKED ROTOR AMPS	THERMAL OVERLOAD TEMP	STATOR WINDING CLASS	CORD LENGTH [FT]	DISCHARGE [IN]	AUTOMATIC
FL152M-2	1.5	208-230	1	1.00	15	53	135°C	B	25	1-1/2 OR 2	NO
FL152M-3		208-230	1	1.00	15	53	135°C	B	35	1-1/2 OR 2	NO
FL152fCM-5		208-230	1	1.00	15	53	135°C	B	50	1-1/2 OR 2	NO
FL152A-2	1.5	208-230	1	1.00	15	53	135°C	B	25	1-1/2 OR 2	YES
FL153M-2	1.5	208/230	3	1.00	11.4	62	N/A	B	25	1-1/2 OR 2	NO
FL153M-3	1.5	208/230	3	1.00	11.4	62	N/A	B	35	1-1/2 OR 2	NO
FL153M-5	1.5	208/230	3	1.00	11.4	62	N/A	B	50	1-1/2 OR 2	NO
FL154M-2	1.5	440-480	3	1.00	5.7	31	N/A	B	25	1-1/2 OR 2	NO
FL154M-3	1.5	440-480	3	1.00	5.7	31	N/A	B	35	1-1/2 OR 2	NO
FL154M-5	1.5	440-480	3	1.00	5.7	31	N/A	B	50	1-1/2 OR 2	NO
FL155M-2	1.5	575	3	1.00	4.9	24	N/A	B	25	1-1/2 OR 2	NO
FL155M-3	1.5	575	3	1.00	4.9	24	N/A	B	35	1-1/2 OR 2	NO
FL155M-5	1.5	575	3	1.00	4.9	24	N/A	B	50	1-1/2 OR 2	NO

## FL150-Series Control Panel Information

PUMP MODEL	SX-SERIES 3-FLOAT NEMA 1	SX-SERIES 3-FLOAT NEMA 4X	AE-SERIES 3-FLOAT NEMA 1	AE-SERIES 4-FLOAT NEMA 1	AE-SERIES 3-FLOAT NEMA 4X	AE-SERIES 4-FLOAT NEMA 4X	IPS-SERIES	IPD-SERIES
	SIMPLEX		DUPLEX				SIMPLEX	DUPLEX
FL152M	SXH21=3	SXH24=3	AE21H=3	AE21H=4	AE24H=3	AE24H=4	IPS-24H	IPD-24H
FL153M	—	SX34=3-511	—	—	AE34=3-511	AE34=4-511	IPS-34-511	IPD-34-511
FL154M	—	SX34=3-171	—	—	AE34=3-171	AE34=4-171	IPS-34-171	IPD-34-171
FL155M	—	SX54=3-161	—	—	AE54=3-161	AE54=4-161	IPS-54-161	IPD-54-161

## FL150-Series Technical Data

---

IMPELLER	2 VANE, SEMI-OPEN CLASS 25 CAST IRON
SOLIDS HANDLING	3/4"
PAINT	POWDER COAT
MAX LIQUID TEMP	
CONTINUOUS DUTY	40°C / 104°F
INTERMITTENT	60°C / 140°F
MAX STATOR TEMP	135°C / 275°F
THERMAL OVERLOAD	1-PHASE - 135°C / 275°F
POWER CORD TYPE	
1-PHASE	SJOOW
3-PHASE	SEOOW
MOTOR HOUSING	CLASS 25 CAST IRON
VOLUTE	CLASS 25 CAST IRON
SHAFT	STAINLESS
HARDWARE	STAINLESS
O-RINGS	BUNA-N
MECHANICAL SEAL	UNITIZED GRAPHITE IMPREGNATED SILICON CARBIDE
WEIGHT	36.7 KG / 81 LB
CERTIFICATIONS	SSPMA, cCSAus

# FL150-Series Specifications

---

## 1.01 GENERAL

---

The contractor shall provide labor, material, equipment, and incidentals required to provide \_\_\_\_\_ (QTY) centrifugal effluent pumps as specified herein. The pump models covered in this specification are FL150-Series single or three-phase effluent pumps. The pump furnished for this application shall be model \_\_\_\_\_ as manufactured by Liberty Pumps.

## 2.01 OPERATING CONDITIONS

---

Each submersible pump shall be rated at 1.5 hp, \_\_\_\_\_ volts, \_\_\_\_\_ phase, 60 Hz, 3450 RPM. The unit shall produce \_\_\_\_\_ GPM at \_\_\_\_\_ feet of total dynamic head.

The submersible pump shall be capable of handling 3/4" solids, enabling pumping over long distances in pipelines as small as 1-1/2" in diameter. The submersible pump shall have a shut-off head of 110 feet and a maximum flow of 123 GPM @ 10 feet of total dynamic head.

The pump shall be controlled with:

- \_\_\_\_\_ A piggyback style ON/OFF float switch
- \_\_\_\_\_ A NEMA 4X outdoor simplex control panel with three float switches including a high water alarm
- \_\_\_\_\_ A NEMA 4X outdoor duplex control panel with three float switches including a high water alarm

## 3.01 CONSTRUCTION

---

Each centrifugal effluent pump shall be equal to the  Certified FL150-Series effluent pumps as manufactured by Liberty Pumps, Bergen NY. The castings shall be constructed of class 25 cast iron. The motor housing shall be oil-filled to dissipate heat. Air-filled motors shall not be considered equal since they do not properly dissipate heat from the motor. All mating parts shall be machined and sealed with a Buna-N O-ring. All fasteners exposed to the liquid shall be stainless steel. The motor shall be protected on the top side with sealed cord entry plate with molded pins to conduct electricity, eliminating the ability of water to enter internally through the cord. The motor shall be protected on the lower side with a dual seal arrangement. The first seal is a double lip seal molded in FKM fluoroelastomer or Buna-N. The second/main seal shall be a unitized graphite impregnated silicon carbide hard face with stainless steel housings and spring.

The upper and lower bearing shall be capable of handling all radial thrust loads. The lower bearing shall have the additional ability to handle the downward axial thrust produced by the impeller by design of angular contact roller races. The pump housing shall be of the concentric design thereby equalizing the pressure forces inside the housing that extends the service life of the seals and bearings. Additionally there shall be no cutwater in the housing volute in order to discourage the entrapment of flowing debris. The pump shall be furnished with stainless steel handle having a nitrile grip.

## 4.01 ELECTRICAL POWER CORD

---

The submersible pump shall be supplied with length of multi-conductor power cord as per **Electrical Data** table. It shall be cord type SJOOW (1-phase) or SEOOW (3-phase), capable of continued exposure to the pumped liquid. The power cord shall be sized for the rated full load amps of the pump in accordance with the National Electric Code. The power cord shall not enter the motor housing directly but will conduct electricity to the motor by means of a watertight compression fitting cord plate assembly with molded pins to conduct electricity. This eliminates the ability of water to enter internally through the cord via a damaged or wicking cord.

## **5.01 MOTORS**

---

Single-phase motors shall be oil-filled, split-phase, capacitor start, class B insulated NEMA B design, rated for continuous duty. Three-phase motors shall be polyphase. At maximum load the winding temperature shall not exceed 135°C un-submerged. Since air-filled motors are not capable of dissipating heat they shall not be considered equal. Single-phase motors shall have an integral thermal overload switch in the windings for protecting the motor. Three-phase motors shall be used with an appropriate controller with integral overload protection. The capacitor circuit on single-phase motors shall be mounted internally in the pump. Single-phase motors shall have an integral solid-state starting circuit switch for switching the start winding off.

## **6.01 BEARINGS AND SHAFT**

---

An upper radial and a lower thrust bearing shall be required. The upper bearing shall be a single ball/race type bearing. The lower bearing shall be an angular contact heavy-duty ball/race type bearing, designed to handle axial pump thrust loads. Both bearings shall be permanently lubricated by the oil that fills the motor housing. The motor shaft shall be made of 300 or 400 series stainless steel and have a minimum diameter of 0.670".

## **7.01 SEALS**

---

The pump shall have a dual seal arrangement consisting of a lower and upper seal to protect the motor from the pumping liquid. The lower seal shall be a FKM fluoroelastomer or Buna-N molded double lip seal designed to exclude foreign material away from the main upper seal. The upper seal shall be a unitized graphite impregnated silicon carbide hard face seal with stainless steel housings and spring. The motor plate/housing interface shall be sealed with a Buna-N O-ring.

## **8.01 IMPELLER**

---

The impeller shall be a class 25 cast iron 2 vane impeller, with pump out vanes on the back shroud to keep debris away from the seal area. It shall be screw mounted to the motor shaft with a bonding agent.

## **9.01 CONTROLS**

---

All single-phase units can be supplied with CSA and UL approved automatic wide-angle tilt float switches. The switches shall be equipped with piggyback style plug that allows the pump to be operated manually without the removal of the pump in the event that a switch becomes inoperable. Manual pumps are operable by means of a pump control panel.

## **10.01 PAINT**

---

The exterior of the casting shall be protected with powder coat paint.

## **11.01 SUPPORT**

---

The pump shall have cast iron support legs enabling it to be a freestanding unit. The legs will be high enough to allow 3/4" solids handling.

## **12.01 SERVICEABILITY**

---

Components required for the repair of the pump shall be shipped within a period of 24 hours.

### **13.01 FACTORY ASSEMBLED TANK SYSTEMS WITH GUIDE RAIL AND QUICK DISCONNECT DISCHARGE**

- Factory mounted guide rail system with pump suspended by means of thread-on quick disconnect that is sealed by means of nitrile grommets or O-rings. The discharge piping shall be Schedule 80 PVC and furnished with a check valve and PVC shut-off ball valve. The tank shall be wound fiberglass or roto-molded plastic. An inlet hub shall be provided with the system.
- Stainless steel guide rail
- Zinc plated steel guide rail
- Diameter of basin in inches
- Height of basin in inches
- Distance from top of tank to discharge pipe outlet in inches
- Fiberglass cover
- Structural foam polymer cover
- Steel cover
- Simplex system with outdoor panel and alarm
- Duplex system with outdoor panel and alarm
- Separate outdoor alarm
- Remote outdoor alarm

### **14.01 TESTING**

The pump shall have a ground continuity check and the motor chamber shall be hi-potted to test for electrical integrity, moisture content and insulation defects. The motor and volute housing shall be pressurized and an air leak decay test performed to ensure integrity of the motor housing. The pump shall be monitored for run voltage and current, and checked for noise or other malfunction.

### **15.01 QUALITY CONTROL**

The pump shall be manufactured in an ISO 9001 certified facility.

### **16.01 WARRANTY**

Standard limited warranty shall be 3 years.